



EXCLUSIVE DEALER

OF LIUGONG PRODUCTS IN WESTERN CANADA



HYDRIVE

Forklift & Equipment Inc.

Model	Capacity	Range	Voltage	Controller
	@ 500mm LC	@ 24" LC		
2015AT	1,500 kg	3,000 lbs	48 volt	SME AC (Italy)
2018AT	1,800 kg	3,500 lbs	48 volt	SME AC (Italy)

2015-18AT

FORKLIFTS



TOUGH WORLD. TOUGH EQUIPMENT.

2015-18AT

Electric 3-Wheel Pneumatic Tire Forklifts

			LiuGong		LiuGong			
			2015AT	2018AT	Imperial	Metric		
General	1	Make	LiuGong		LiuGong			
	2	Model	2015AT		2018AT			
	3	Power Type	Electric		Electric			
	4	Unit of Measure	Imperial	Metric	Imperial	Metric		
	5	Operator Type	Sit-Down Rider		Sit-Down Rider			
Weights	6	Base Capacity	@ rated load center	lbs [kg]	3000	1500	3500	1800
	7	Load Center		in [mm]	24.0	500	24.0	500
	8	Service Weight	unloaded with minimum weight battery	lbs [kg]	6724	3050	7275	3300
	9	Axle Load	loaded, front	lbs [kg]	8801	3992	9936	4507
10	loaded, rear		lbs [kg]	1230	558	1307	593	
11	unloaded, front		lbs [kg]	3355	1522	3415	1549	
12		unloaded, rear	lbs [kg]	3369	1528	3860	1751	
Tires	13	Tire Type			Solid tire		Solid tire	
	14	Wheels	front / rear		2 / 2		2 / 2	
	15	Wheelbase		in [mm]	52.8	1340	52.8	1340
	16	Tire Size	front		18x7-8		200/50-10	
	17		rear		15x4.5-8		15x4.5-8	
	18	Tread Width	front		36.4	925	36.0	915
19	rear			7.1	180	7.1	180	
Mast	20	Max. Fork Height	with std 2-stage mast	in [mm]	118.1	3000	118.1	3000
	21	Freelift	with std 2-stage mast	in [mm]	5.3	135	5.3	135
	22	Height, Upright Lowered	with std 2-stage mast	in [mm]	80.5	2045	80.5	2045
	23	Height, Upright Extended	with std 2-stage mast	in [mm]	161.0	4090	161.0	4090
	24	Mast Tilt, Fwd/Back	with std 2-stage mast	deg	6° / 7°		6° / 7°	
	25	Carriage	ISO Class		II		II	
	26		width	in [mm]	40.9	1040	40.9	1040
	27	Fork Spread	minimum	in [mm]	8.7	222	8.7	222
	28		maximum	in [mm]	39.8	1010	39.8	1010
	29	Fork Dimensions	T x W x L	in	1.4 x 3.9 x 36.2		1.4 x 3.9 x 36.2	
30			mm	35 x 100 x 920		35 x 100 x 920		
Chassis	31	Length to Fork Face	with std 2-stage mast	in [mm]	76.2	1935	77.6	1970
	32	Overall Width		in [mm]	43.7	1110	43.7	1110
	33	Overhead Guard Height		in [mm]	79.7	2025	79.7	2025
	34	Turning Radius	minimum outside	in [mm]	61.0	1550	63.2	1605
	35	Fork Overhang	with std 2-stage mast	in [mm]	15.2	385	15.2	385
	36	Right Angle Stack	add load length and clearance	in [mm]	79.3	2015	81.5	2070
	37	Ground Clearance	minimum loaded	in [mm]	2.4	60	2.4	60
	38		center of wheelbase	in [mm]	4.1	105	4.1	105
	39	Battery Compartment	length (front-to-back)	in [mm]	22.8	580	22.8	580
	40		width (side-to-side)	in [mm]	33.3	845	33.3	845
	41		height	in [mm]	28.3	720	28.3	720
Performance	42	Travel Speed	loaded	mph[km/h]	9.3	15	9.3	15
	43		unloaded	mph[km/h]	9.3	15	9.3	15
	44	Lift Speed	loaded	fpm[m/s]	68.9	0.35	68.9	0.35
	45		unloaded	fpm[m/s]	98.4	0.5	98.4	0.5
	46	Lower Speed	loaded	fpm[m/s]	98.4	0.5	98.4	0.5
	47		unloaded	fpm[m/s]	78.7	0.4	78.7	0.4
	48	Max. Drawbar Pull	5 min. rating	lbs [kg]	2811	1275	2811	1275
	49		60 min. rating	lbs [kg]	697	316	664	301
	50	Max. Gradeability	5 min. rating	%	20		20	
	51		60 min. rating	%	5.2		3.8	
Systems	52	Brakes	service		Foot / Wet Disc		Foot / Wet Disc	
	53		parking		Hand / Mech		Hand / Mech	
	54	Controllers	drive (make, type)		SME, AC		SME, AC	
	55		hydraulic (make, type)		SME, AC		SME, AC	
	56	Motors	drive output (60 min. rating)×2	HP[kw]	8.7	6.5	8.7	6.5
	57		hydraulic output (15 min. rating)	HP[kw]	20.1	15	20.1	15
	58	Battery	type		Lead Acid		Lead Acid	
	59		voltage		48		48	
	60		max. capacity (6 hour rating)	Ah[kwh]	480	23.1	540	25.9
	61	Hydraulic Pressure	weight, minimum	lbs [kg]	1433	650	1543	700
	62		weight, maximum	lbs [kg]	2028	920	2028	920
	63	Hydraulic Pressure	system	psi[bar]	2103	145	2509	173
	64		attachment	psi[bar]	2103	145	2509	173

Note: Dimension and specs are nominal values.

AVAILABLE OPTIONS

Contact your local LiuGong distributor for more information on the options available for your application. Some options may not be available in all markets.

- Standard two-stage mast
- Sideshifter carriage
- Dual function auxiliary hydraulics
- Variety of fork styles
- Solid pneumatic tires
- Full suspension system
- Warning lights
- Fire extinguisher

Mast Type	Maximum Fork Height (MFH)	
	mm	in
Standard 2-Stage	3000	118.1
	3300	129.9
	3500	137.8
	4000	157.5
Full Free 2-Stage	3000	118.1
Full Free 3-Stage	4500	177.2
	4800	189.0
	5000	196.9
	5500	216.5
	6000	236.2

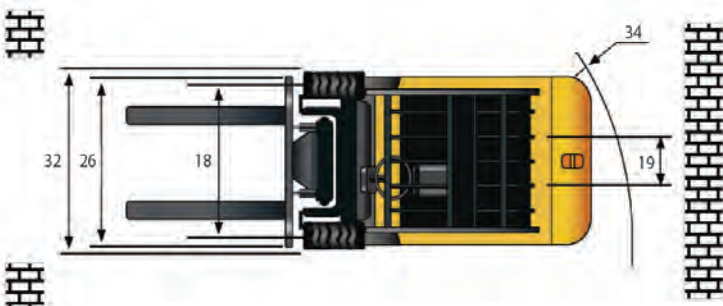
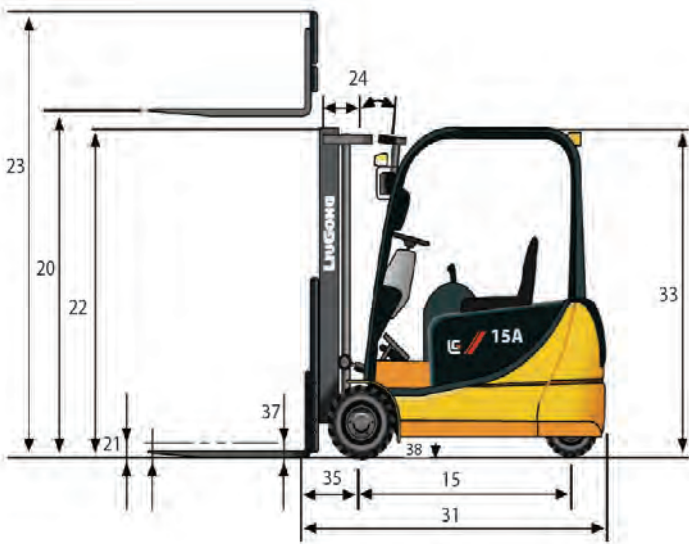

Performance values are subject to change without notice. Performance values and may vary by machine.

OPTIONS

Contact your Liugong dealer for options available to optimize your Liugong forklift to your application. Some of the factory options available are listed here.

- Mast options include single-stage, full-free two-stage and three-stage masts up to 6.0M lift height
- Mast options include 3-stage mast with 3rd stage free lift
- Mast options include auxiliary hydraulic valve and hosing
- Mast options include mast length options
- Mast options include mast width options
- Mast options include mast tip options

Mast Overall Lowered Height (OAL)		Free Lift (FL) with Load Backrest*		Mast Tilt Angle (F/B)	2015AT Total Weight with Standard Forks		2018AT Total Weight with Standard Forks	
mm	in	mm	in	degrees	kg	lbs	kg	lbs
2045	80.5	135	5.3	6 / 7	3050	6724	3300	7275
2195	86.4	135	5.3	6 / 7	3070	6768	3320	7319
2295	90.4	135	5.3	6 / 7	3090	6812	3340	7363
2595	102.2	135	5.3	6 / 7	3115	6867	3365	7418
2045	80.5	965	38.0	6 / 7	3050	6724	3300	7275
2130	83.9	1045	41.1	3 / 6	3445	7595	3695	8146
2230	87.8	1145	45.1	3 / 6	3465	7639	3715	8190
2290	90.2	1205	47.4	3 / 6	3475	7661	3725	8212
2460	96.9	1730	68.1	3 / 6	3560	7848	3810	8400
2835	111.6	1830	72.0	3 / 6	3640	8025	3890	8576

2015-18AT

Electric 3-Wheel Pneumatic Tire Forklifts



DRIVELINE

- SME AC Control System (1)
AC dual drive motors (brushless)
AC hydraulic motor (brushless)

The Italian made SME control system provides state-of-the-art technology for maximum performance and efficiency and features three performance modes. The SME “EYE” diagnostic software allows for quick and accurate parameter changes and diagnostic troubleshooting.

The 100% AC system eliminates motor brushes to maximize performance and minimize maintenance. The dual drive motors allow the drive tires to counter-rotate for exceptional maneuverability.

Sealed wet-disc brakes virtually eliminate down-time and expenses associated with brake adjustment and repairs.

CHASSIS

The frame structure was designed using Computer Aided Engineering (CAE) software for increased strength and durability. Open step and spacious foot room allow for easy access and comfortable operation for the operator.

Heavy duty fabricated steer axle features hydrostatic steering and tapered roller bearings for ease of operation and long service life. The cushion mounted overhead guard minimizes vibration making the operator more comfortable and productive. (2)

The spacious battery compartment allows for battery capacities up to 540Ah for extended operation.

MAST

Our masts feature wide channel spacing and the secondary lift chains and auxiliary hydraulics are mounted at 90 degrees behind

the channels on the three stage masts for improved forward visibility. The fork carriage and mast channels have large side thrust rollers for strength, high reliability and are located for easy service.

OPERATOR COMPARTMENT

The seat side hydraulic controls combine ergonomics and simplicity to provide a cost effective and reliable system that maximizes operator productivity. Directional change is performed via the yellow thumb-switch on the lift lever for easy operation. (5)

The operator presence system provides additional protection for the operator by cutting power to the drive motors and locking out the hydraulic operation when the operator leaves the seat. A warning alarm also notifies the operator to set the park brake before leaving the machine unattended.

The full-suspension seat provides world-class comfort, which is adjustable for weight, leg room and back angle. (3)

The informative instrument panel is mounted on the cowl and features: battery level indicator, hour meter, fault code display, turn signal indicators, system warning, park brake set indicator, low brake fluid, travel speed, OPS function, steer angle indicator and maintenance due indicator. (4)

EXTRAS

The standard light package includes two front combination flood/turn signal lights and the LiuGong rear light bar which features LED turn/brake/back-up lights. All electrical components use automotive style sealed connectors for high reliability.

A STRONG FOUNDATION. A STRONG FUTURE.

LiuGong was founded in 1958 in Liuzhou, China. Since then, we have become one of the world’s most respected, premier heavy equipment and industrial equipment manufacturers. LiuGong engineers simple, serviceable designs that are reliable and remarkably durable.

Today, LiuGong employs more than 14,000 including over 1,000 engineers working in three world-class research and development facilities around the world.

When you purchase a LiuGong machine, you get an easy to own, easy to maintain piece of equipment and you join forces with a company that has spent the past 50 years dedicating itself to making your job easier. Learn more about LiuGong at www.liugongna.com

LIUGONG SERVICE AND SUPPORT, LIKE NO OTHER.

We don’t just provide a world-class machine; we provide all the service and support you need. With over 2,650 sales outlets, 380 dealers, 24 manufacturing facilities, 10 regional parts depots and nine global offices located strategically throughout the world we ensure rapid replacement of parts and servicing of equipment. We have all your local service and support needs covered.

With LiuGong, you know you’ll get the personal attention you deserve because you don’t have time for anything less.

Contact your local LiuGong Forklift dealer for more information.

LiuGong Construction Machinery N.A., LLC

22220 Merchants Way, Suite 100, Katy, Texas 77449

T: (281) 579-8882 F: (281) 579-8388

www.liugongna.com

Specifications and designs are subject to change without notice. Machines shown may include optional equipment.

02/2014 Designed by LiuGong